



Delivering Integrated
Building Solutions
You Can Trust





Trusted manufacturing of Centralized Air Conditioning Ducts & Accessories, Building Management, Security Services, Maintenance Services, Cleaning Services, Fit-out Works and MEP Works!

Crafting excellence in every duct, we stand as your trusted partner in centralized air conditioning systems and more! From seamless manufacturing to top-notch MEP works, we've got your building's comfort covered.



Certified

Setting the standard for excellence in air conditioning ducts! Our commitment to ISO quality assurance ensures precision engineering and reliability in every duct we manufacture and supply. Trust in our expertise for your HVAC needs!

ISO Quality Assurance in the manufacture and supply of ducts for **Air Conditioning System.**



HVAC System

Precision meets customization in our air ducts! From aluminum to stainless steel and galvanized iron, our efficient air ducts are the backbone of your HVAC system. Tailored to perfection, because design matters!

Efficient Air Ducts are an integral part of the HVAC System.

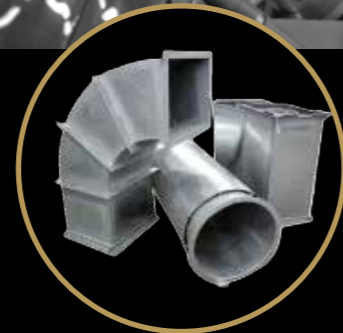

Aluminium (AL) Ducts

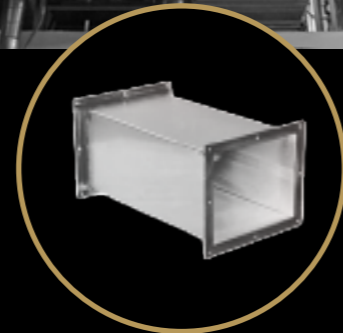

Stainless steel (SS) Ducts



Galvanized Iron (GI) Ducts



Mild Steel (MS) Ducts

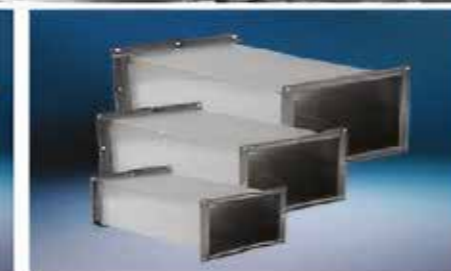

Stainless Steel (SS) Ducts



Pre-Insulated Ducts



Air Ducts

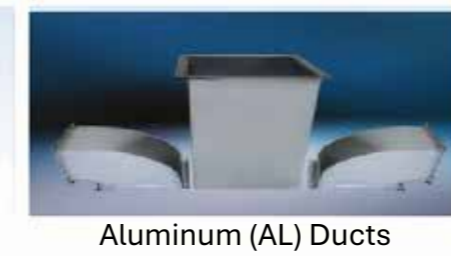

Aluminum (AL) Ducts



Volume Control Damper Access Door

Air Duct Manufacturer

At the company's primary manufacturing facility in Dubai Investment Park 2- , ducts are manufactured to meet stringent HVAC and Industrial specifications and standards such as; DW144/SMACNA/ASHRAE

Trusted FIRE DAMPERS

Manufactured in the UAE

Ensuring safety and compliance in buildings! We're your trusted fire damper manufacturers, delivering top-quality products that meet rigorous safety standards. Connect with us for reliable solutions that prioritize fire protection.

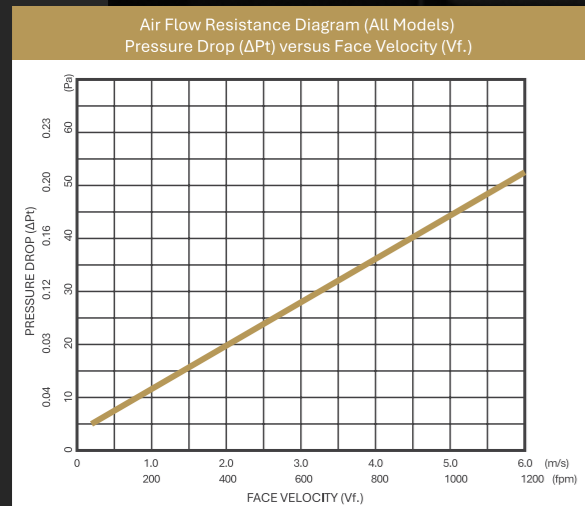

Volume Control Dampers

- AMCA (OHIO) -500D certified
- Dubai & Abu Dhabi Civil Defense approved

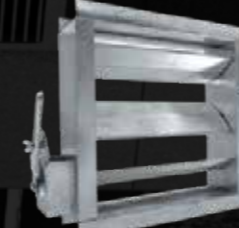

FC-VCD-AL-100

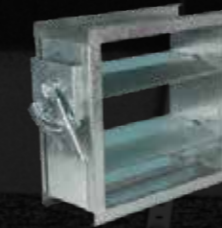

FC-VCD-GI-200



FC-VCD-GI-300-RD

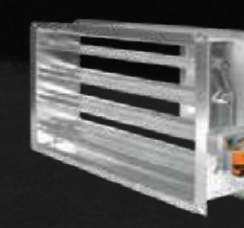

FC-VCD-AL-400-M

Full Circle's Volume Control Dampers or Balancing Dampers are designed to balance air to individual areas. This unit comes with complete manual quadrant or motorized actuators. Volume Control Dampers can be manufactured with galvanized steel, stainless steel and aluminium. Dampers are suitable for the systems requiring air control.

Features:

- Full Circle Dampers are available from 100 mm to 1200 mm for single section, if the size is more than 1200 mm, the dampers will be manufactured in multi-section with single drive or multiple drives as per requirement.
- Pre-punched holes are available for easy installation.
- Blade: Aerofoil, double walled, 1.60 mm equivalent thickness galvanized steel sheet.
- Actuator: Belimo / Honeywell On / Off or spring returns type.

Non Return Dampers



FC-NRD-SD



FC-NRD-RD



FC-NRD-WM

Features:

- Smooth and maintenance free blade operation
- Frame is manufactured from high quality aluminum / galvanized sheet steel of 18 gauge thickness.
- Blades are made of 0.3 mm / 1.00 mm thickness aluminum sheet or galvanized steel sheet.
- Blades are fitted with nylon bushes for rattle free and smooth operation.
- Blades are sealed with foam / rubber gasket at the bottom to avoid rattling noise and provide air tight operation.
- Frame is fitted with aluminium strip to prevent the over movement of the blades.
- Additional centre partition shall be provided if height or length is more than 900 mm.

Our manufacturing company specializes in non return dampers designed to optimize ventilation systems. These dampers ensure one-way airflow, preventing the backflow of air and maintaining efficient ventilation in various environments. Crafted from high-quality materials, such as galvanized steel or aluminum, our non return dampers offer durability and reliability. They are available in a range of sizes and configurations to suit different ductwork systems. With easy installation and low maintenance requirements, our non return dampers enhance indoor air quality while improving energy efficiency. Trust us to enhance the performance of your ventilation systems for optimal airflow management.

DUCT ACCESS DOOR

Fast and secure installation

Unlocking efficiency with fast and secure duct access doors! Our innovative solutions ensure quick installation without compromising on security. Experience seamless access to your ductwork with our trusted products!



Duct Access Doors

Access Doors



FC-AD-25



FC-ADH-25



FC-ADH-C-25

Features:

- Piano hinges: Continuous piano hinges are provided on one side of the door.
- Safety chain is provided as an additional safety feature.

S/N	AVAILABLE SIZES
1	4" x 4"
2	4" x 6"
3	6" x 6"
4	6" x 8"
5	8" x 8"
6	10" x 8"
7	10" x 10"
8	12" x 10"
9	12" x 12"
10	14" x 14"

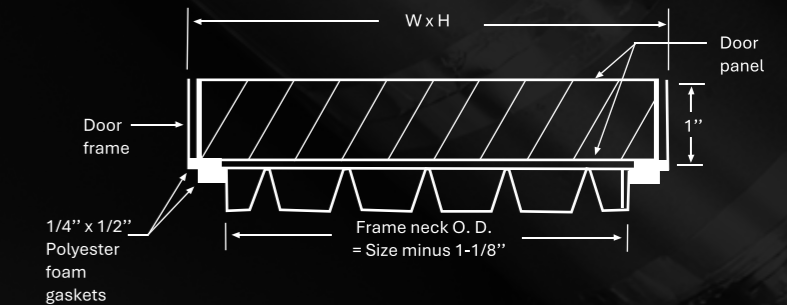

KITCHEN EQUIPMENT

Where Quality Meets Kitchen Innovation

- Advance Cooking Tools
- Innovative Ovens
- State-of-the-art Coffee Equipment
- High-Performance Juice Machines
- Custom Fabrication Options
- Bakery Prep Solutions
- Ice-makers and Dishwashers
- Cutting-Edge Refrigerations
- Dynamic Prep Tools
- Diverse Miscellaneous Equipment

Testimonials

Full Circle's kitchen equipment transformed our culinary experience. Precision and durability redefine our kitchen operations.

Sarath Johnson - Head Chef

(Culinary Delights Restaurants)

The seamless access doors from the Full Circle simplified our maintenance tasks. Efficient and reliable solutions for a busy corporate environment.

Emily Cheng

(Facilities manager global office solutions)

Kitchen Equipment

Explore our extensive range of kitchen equipment designed to cater to the unique requirements of various culinary establishments. From cutting-edge cooking equipment and ovens to bakery preparation

tools, icemakers, dishwashers, coffee equipment, refrigeration solutions, juice machines, dynamic prep tools, custom fabrication, and miscellaneous accessories – we have it all.



Hot Plate Range



Open Burner Range



Griddle/ Fry Top



Lava Stone Grill



Solid Top



Fryer



Pasta Cooker



Bratt Pan



Boiling Pan



Induction Range



Chinese Range



Indian Range



Double Shawarma Machine



Gas Shawarma Machine (Table Top)



Electric Shawarma Machine (Table Top)



Salamander



Chicken Grill



Gas Friddle (Table Top)



Electric Griddle (Table Top)



Saj cooker



Double Tank Fryer



Single Tank Fryer



Double Panini Grill



Porota Hot Plate



Professional Induction Cooker

Comprehensive Selection of Ovens

Look at a variety of ovens that can meet a variety of culinary requirements. Full Circle has a wide range of options, from high-capacity ovens ideal for commercial environments to sleek and compact models for contemporary kitchens. With their cutting-edge features, simple controls, and energy-saving technologies, our ovens deliver a flawless cooking experience each and every time. Our manufacturing facility, located in Dubai, epitomizes the innovative and sophisticated character of the city. Full Circle's convection ovens in Dubai, which blend state-of-the-art technology and sophisticated design, perfectly capture Dubai's dedication to quality. Our goods are a perfect example of how fine craftsmanship and the vibrant spirit of Dubai can coexist.



Ovens



Three Deck Oven (Pastry)



Two Deck Oven (Pizza)



Conveyor Oven



Rotary Oven



Combi Oven



Convection Oven



Mandi Oven



Gas Oven



Arabic Oven



Tandoor Oven

Bakery Equipment

At Full Circle, we are aware of the delicate dance of passion and perfection that goes into making mouthwatering baked goods. Our line of bakery equipment in Dubai is expertly designed to take your culinary creations to new heights, from the delicate artistry of pastry-making to the demanding demands of bread production.



Pizza Dough Roller



Dough Sheeter



Table Top Planetary Mixer



Planetary Mixer



Spiral Mixer

Ice Maker Machine & Dishwashers

Our manufacturing business specializes in dishwashers and ice makers made for commercial kitchens. Our products are made using premium materials and cutting-edge technology, with an emphasis on performance and durability. For busy restaurants and bars, our commercial ice maker machines in Dubai swiftly generate large amounts of ice. Comparatively, our dishwashers are

built to be very effective, able to manage large loads and consistently produce spotless dishes. Whether it's to keep drinks cold or uphold the highest hygiene requirements, our sturdy and dependable equipment makes sure that professional kitchen settings run smoothly.



Ice Cube Maker



Ice Flaker



Ice Cream Machine Double + Mix Flavor



Fried Ice Cream



Hard Ice Cream Maker



Glass Washer



Undercounter Dishwasher



Hood Type Dishwasher



Pot Wash Machine



Conveyor Dishwasher

Cold room and Freezers

At Full Circle, we are aware of the delicate dance of passion and perfection that goes into making mouthwatering baked goods. Our line of bakery equipment in Dubai is expertly designed to take your culinary creations to new heights, from the delicate artistry of pastry-making to the demanding demands of bread production.



Double Solid Doors Chiller/ Freezer



Double Glass Doors Chiller/ Freezer



Single Solid Doors Chiller/ Freezer



Single Glass Doors Chiller/ Freezer



U?C Solid Doors Type Chiller/ Freezer



U/C Drawer Type Chiller/ Freezer



U/C Glass Doors Type Chiller/ Freezer



Low Height Chiller



Blast Chiller/ Shock Freezer

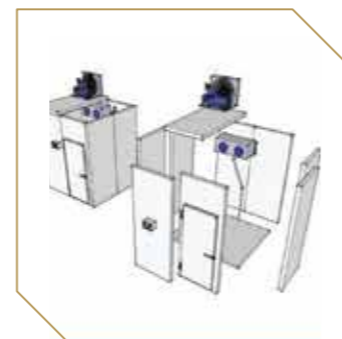

Cold Rooms



Sushi Display



Saladette (Table Top)



Salad/ Pizza Prep



Bain Marie with Sneezed Guard



Bain Marie



Salad Bar (Buffet)



Bar Cooler (Painted)



Cake Display (Curved)



Grab & Go Display



Open Multi Deck Chiller

Commercial Coffee Equipment

Dubai's vibrant cafe culture demands exceptional coffee, and that requires the right tools. As a leading kitchen equipment supplier in the UAE, we understand the importance of choosing the perfect commercial coffee machine for your business. Whether you're a bustling cafe, a cozy coffee shop, or a high-end hotel, we have the expertise and equipment to elevate your coffee experience.

Juice Dispenser & Blender

As a leading kitchen equipment manufacturer in the UAE, we understand the growing demand for fresh, delicious juices in various settings. From bustling restaurants and cafes to health-conscious offices and vibrant hotels, having the best juicer in Dubai plays a crucial role in providing convenient and refreshing beverage options.



3-Group Coffee Machine



2-Group Coffee Machine



1-Group Coffee Machine



Water Boilers



Coffee Grinder



Slush Machine



Juice Dispenser



Classic Citrus Juicer



Silent Blender



Bar Blender

Unleash Culinary Mastery with Full Circle's Dynamic Preparation Equipment

Step into the world of dynamic culinary preparation with Full Circle Central Air Conditioning Requisites Manufacturing LLC, your trusted partner in elevating kitchen efficiency in Dubai, UAE. Our range of cutting-edge preparation equipment is meticulously crafted to empower chefs and culinary enthusiasts alike, ensuring precision and excellence in every aspect of dynamic preparation.

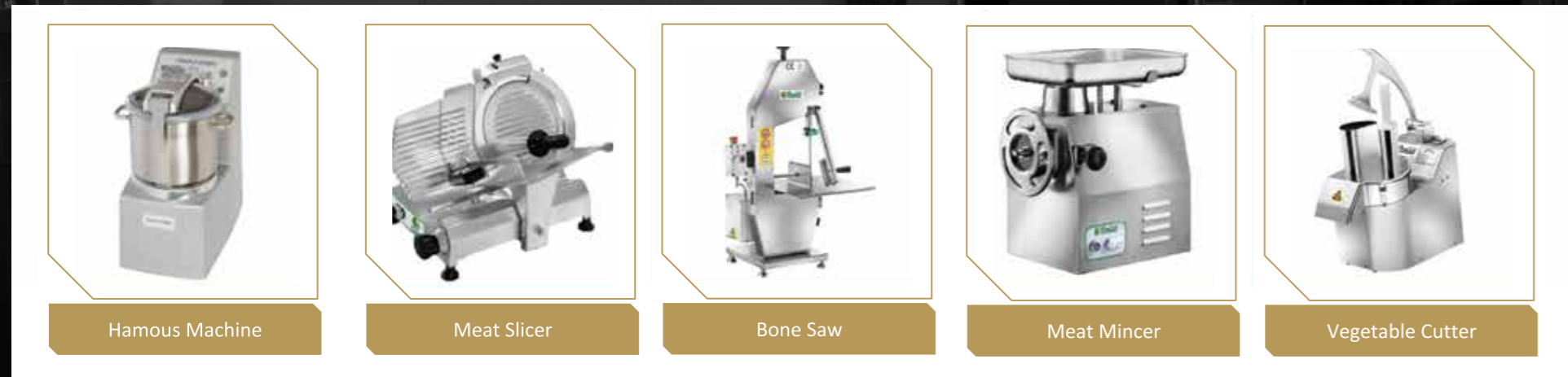

Hamous Machine

Meat Slicer

Bone Saw

Meat Mincer

Vegetable Cutter

Kitchen Equipment Custom Fabrication

Embark on a journey of culinary customization with Full Circle Central Air Conditioning Requisites Manufacturing LLC, your dedicated partner in crafting bespoke culinary spaces in Dubai, UAE. Our range of Custom Fabrication Equipment is meticulously designed to cater to the unique needs of your kitchen, offering precision, functionality, and aesthetic appeal.



Chopping Block

Work Table

Base Cabinet (Sliding)

Wall Cabinet (Sliding)

Wall Shelf

Hood

Island Type Kitchen Hood

Heated Cabinet

Salad Bar

Sink Cabinet

Custom Culinary Craftsmanship:

Situated in Dubai, our manufacturing facility embodies the city's spirit of innovation and sophistication. Full Circle's Custom Fabrication Equipment reflects Dubai's commitment to excellence, offering tailored solutions that align with the city's dynamic culinary landscape.



Sink Unit



Prewash Sink



Exit Table



Service Trolley



Platform Trolley



Hand Wash Sink



Mop And Hand Wash Sink



Floor Grating



Kitchen Hood Filter



Grease Trap





FULL CIRCLE
CENTRAL AIR CONDITIONING

P.O. Box : 500069, Dubai, UAE
Email : info.fcc@fullcirclegroup.ae
Telephone : +971 4 330 7633
Toll FREE : 800 100 200
Address : Office 713, 7th floor,
Blue Bay Tower, Business Bay
Dubai, U.A.E.

